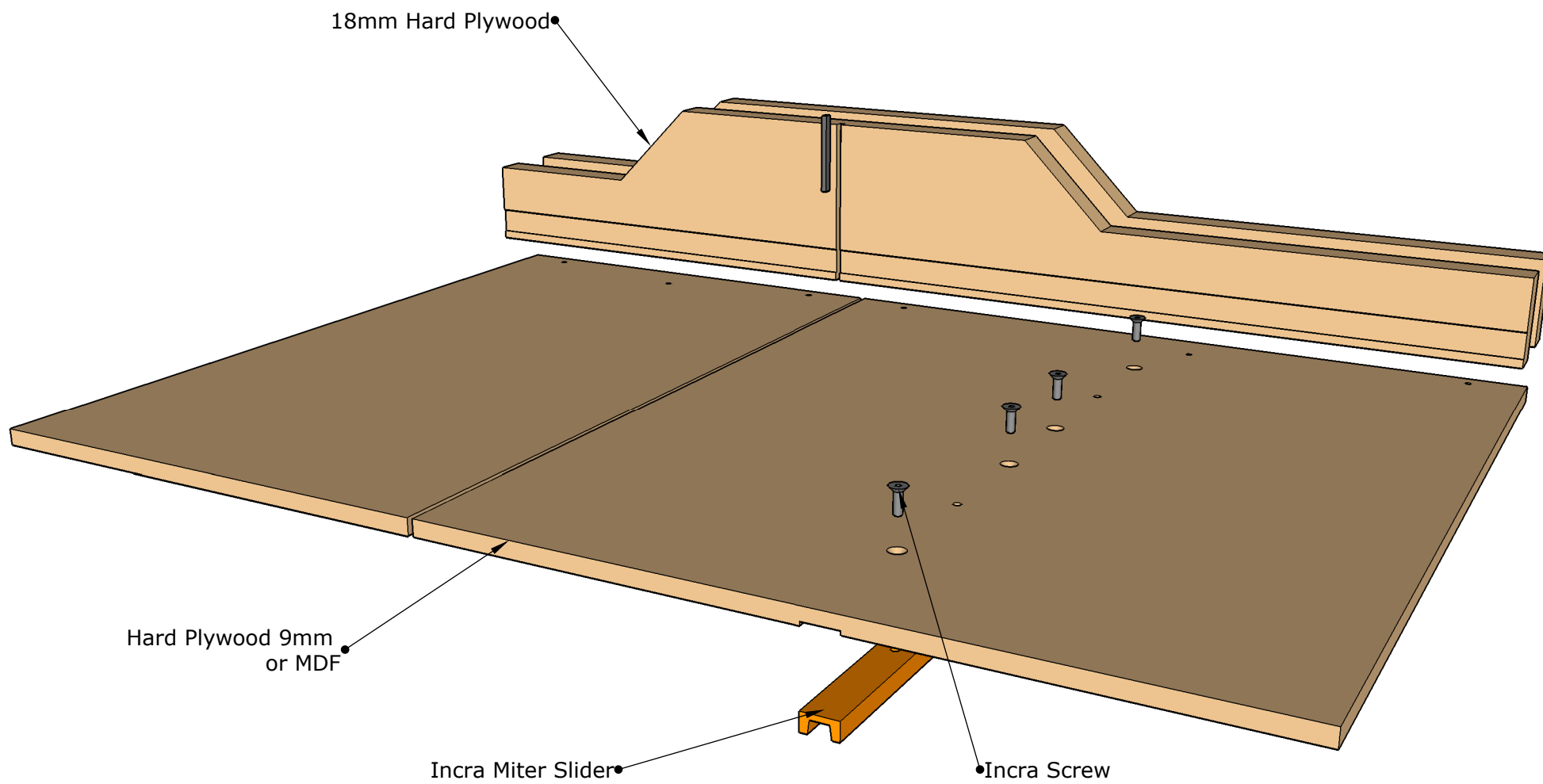

Table Saw Sled - ISO



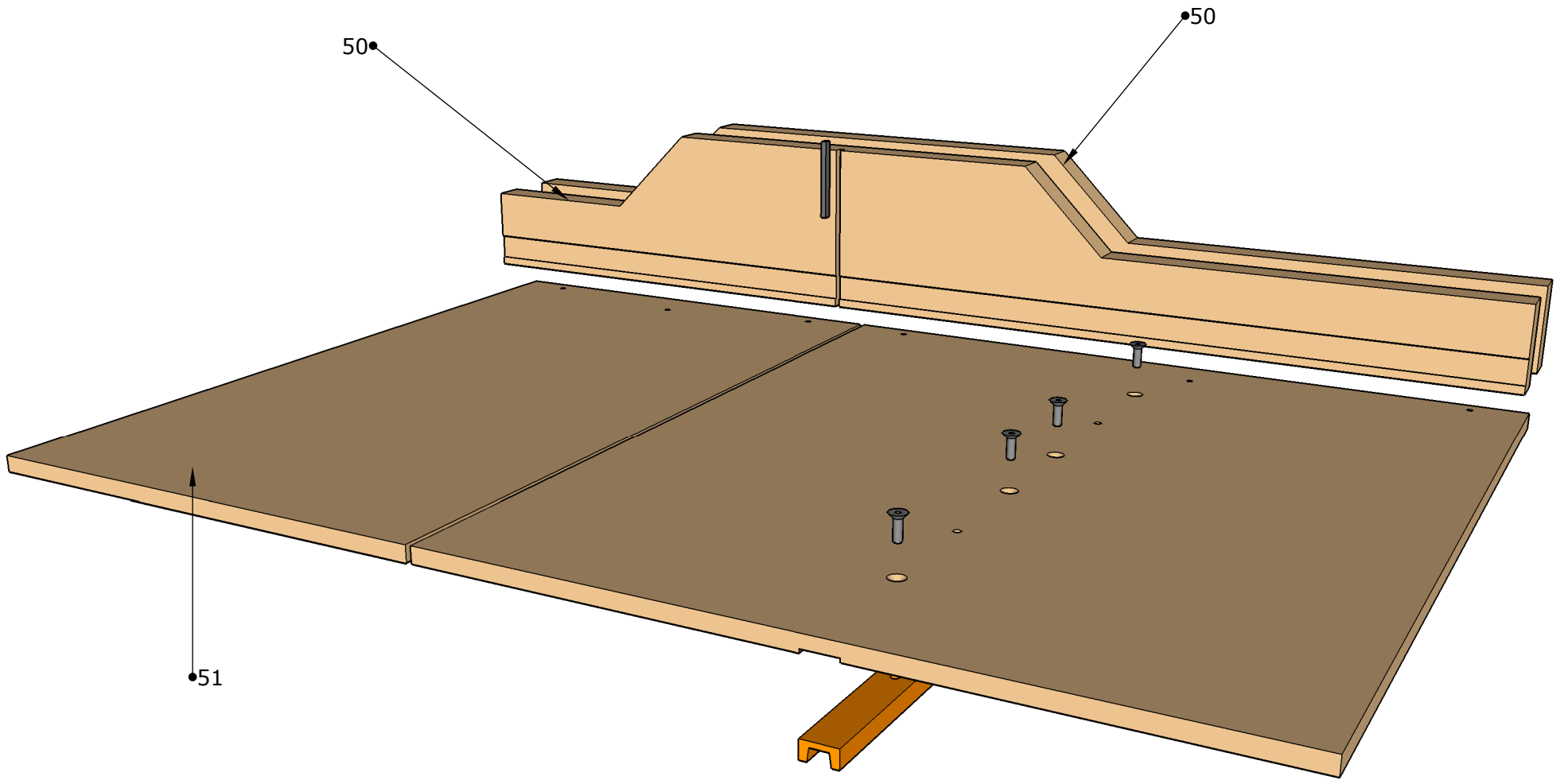

Table Saw Sled

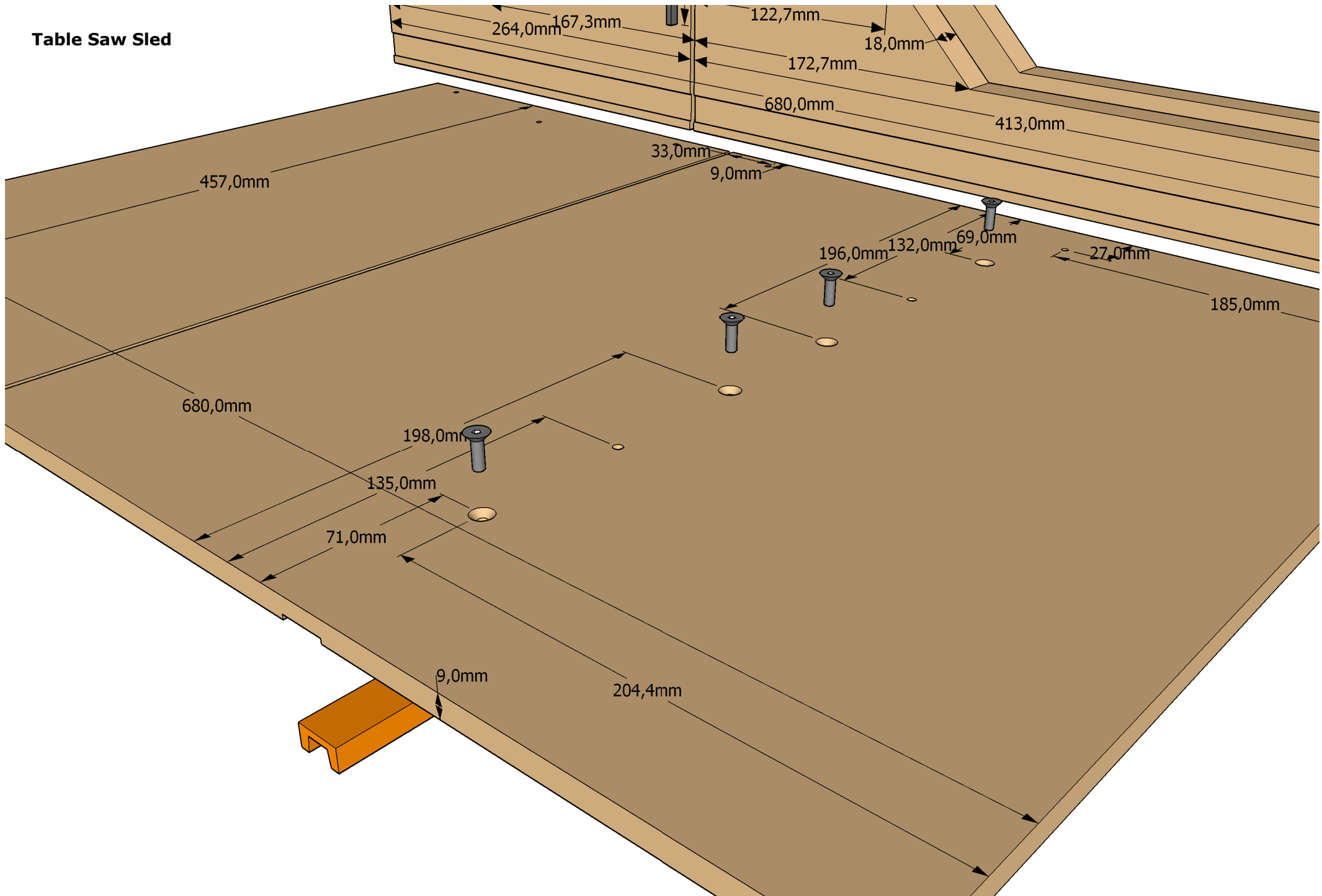

Table Saw Sled - Mill

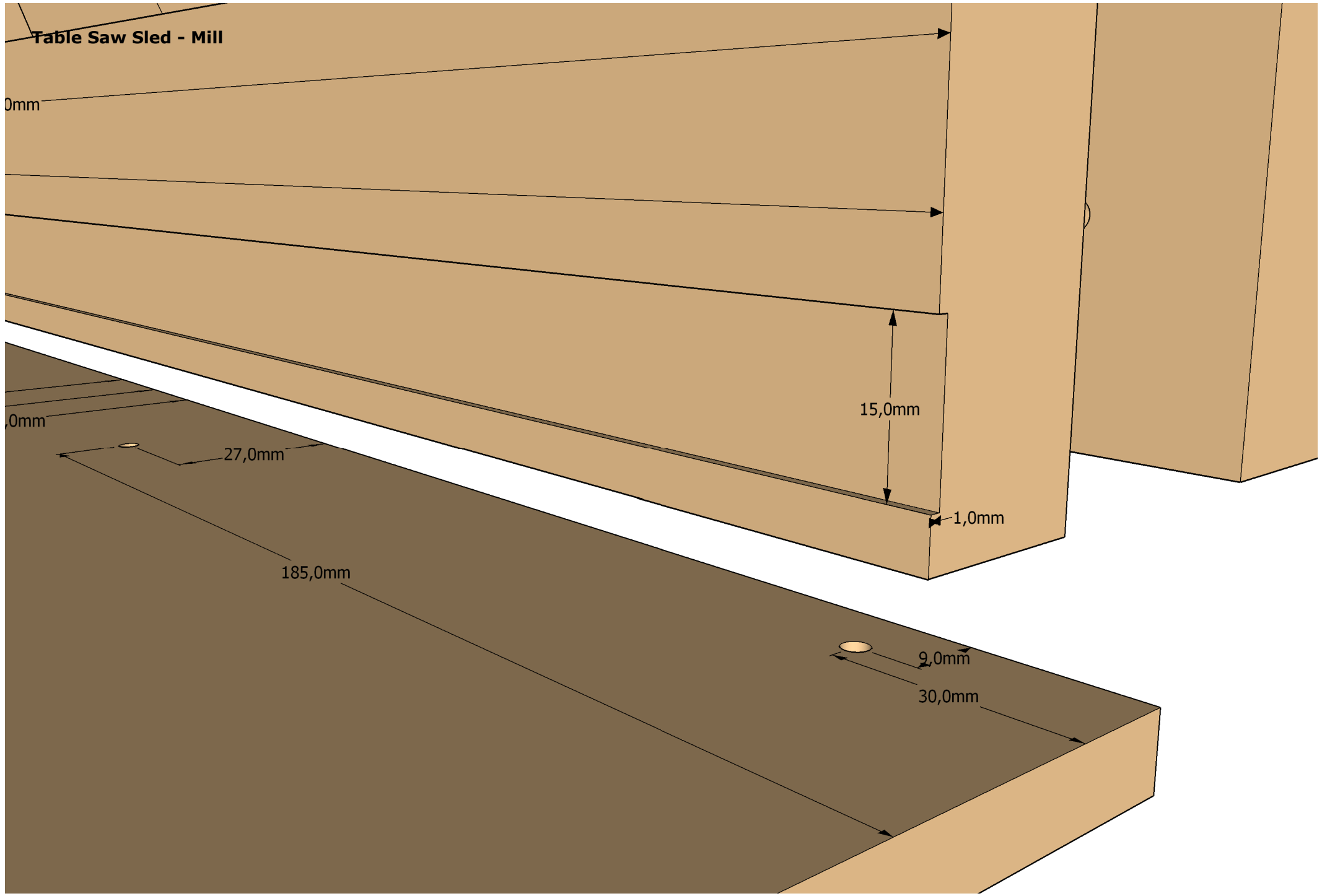

Table Saw Sled

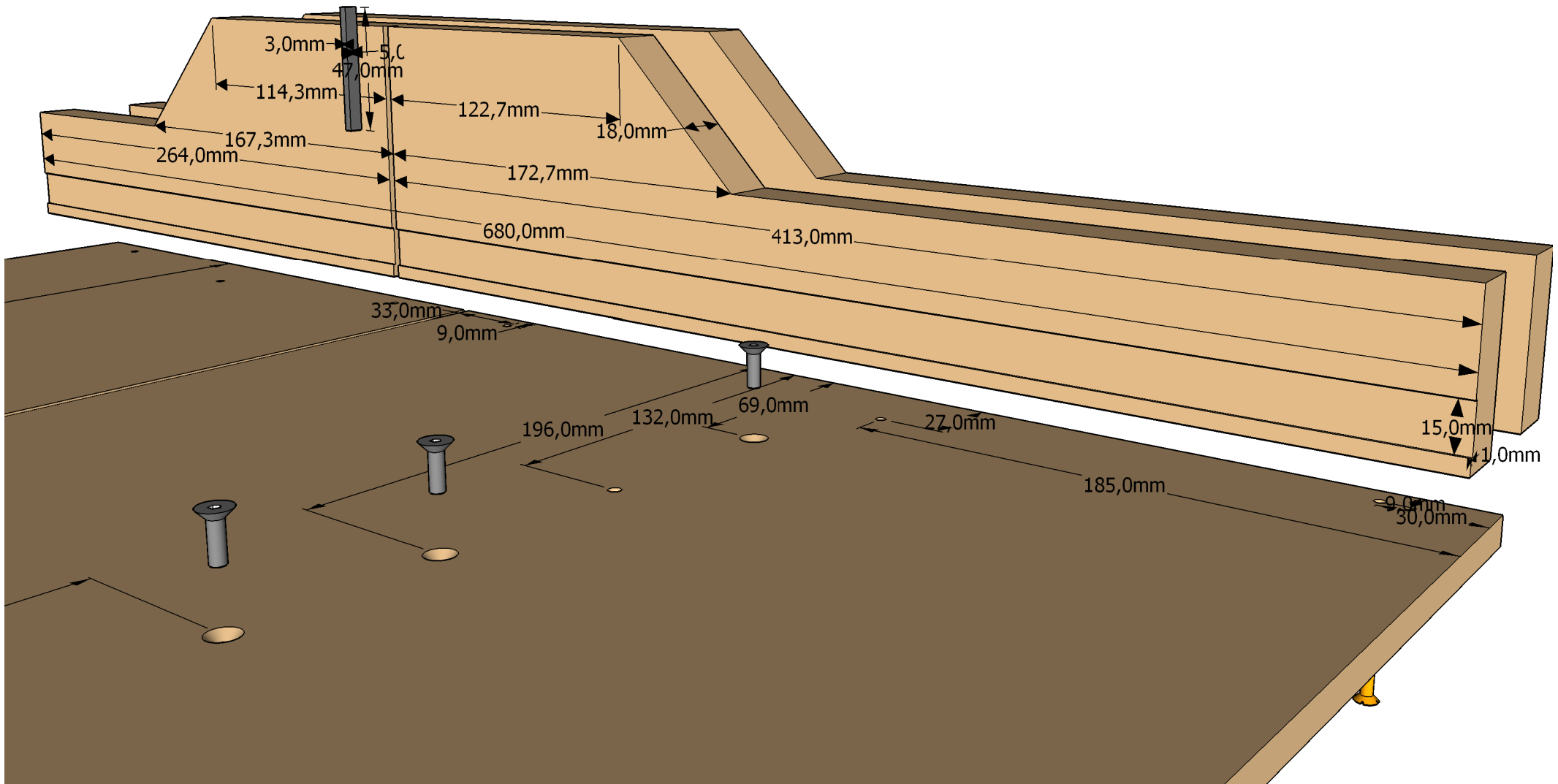

Table Saw Sled - Stick

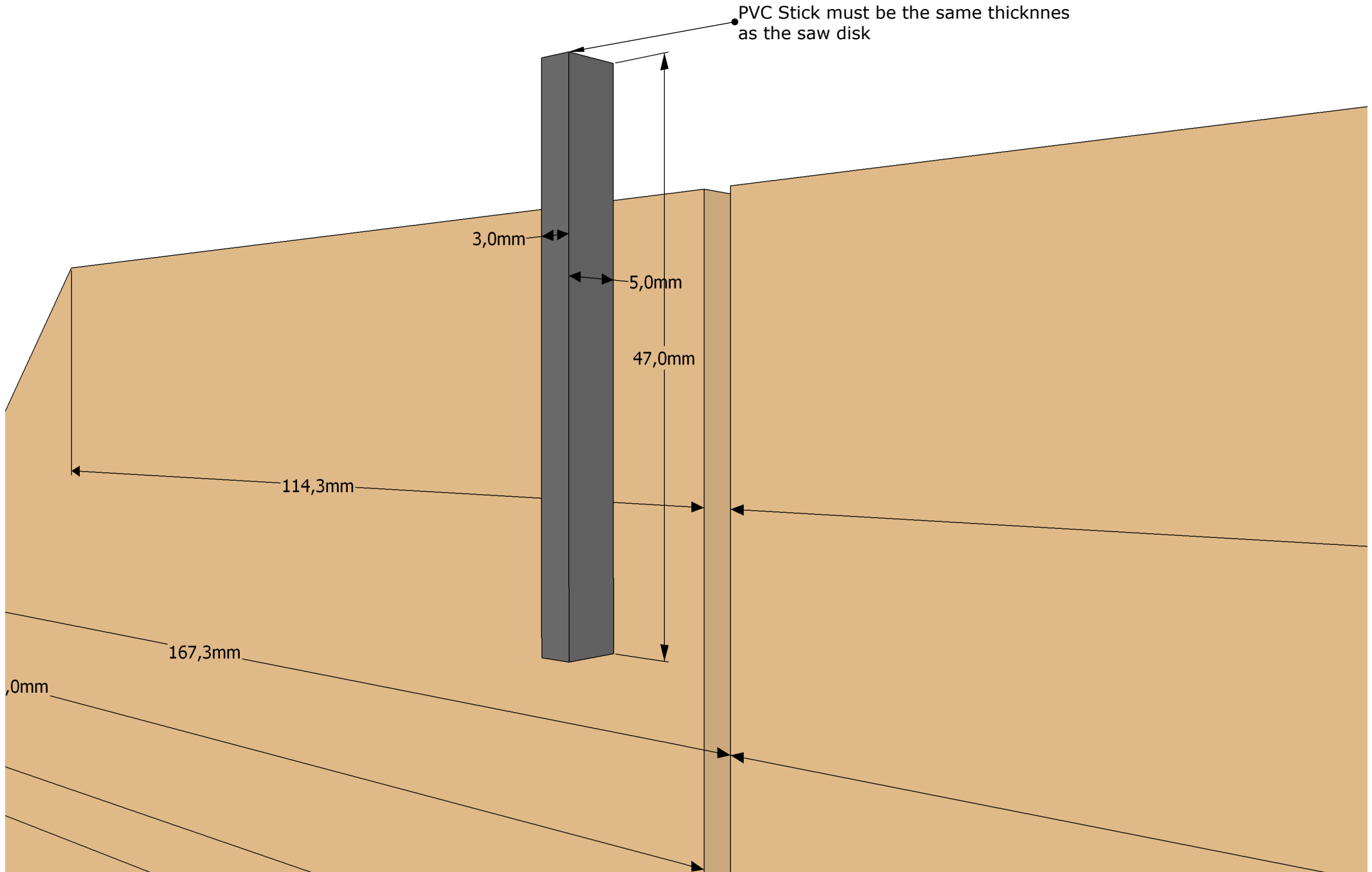

Table Saw Sled - Top 1/3 Scale

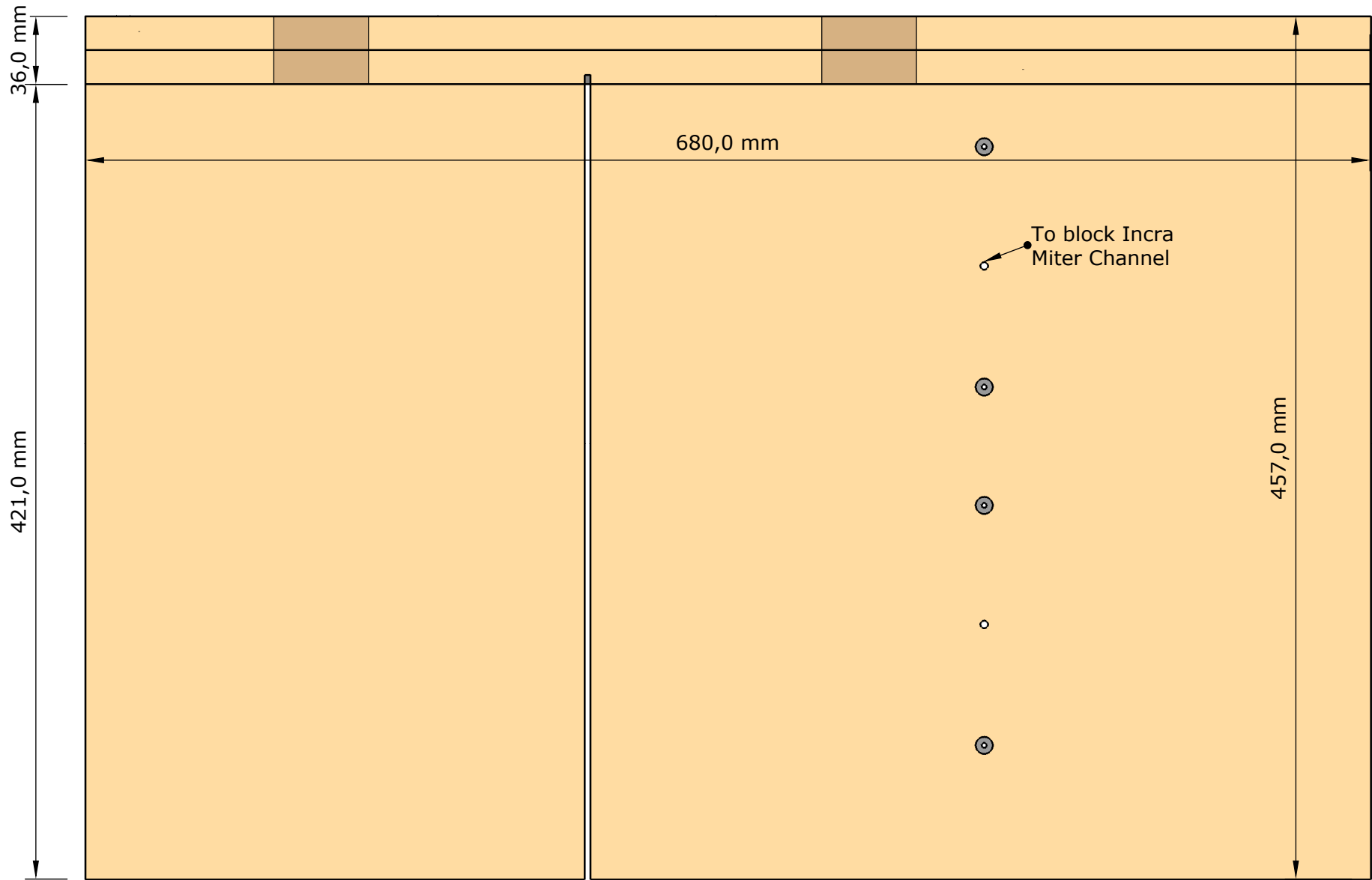

Table Saw Sled - Front 1/3 Scale

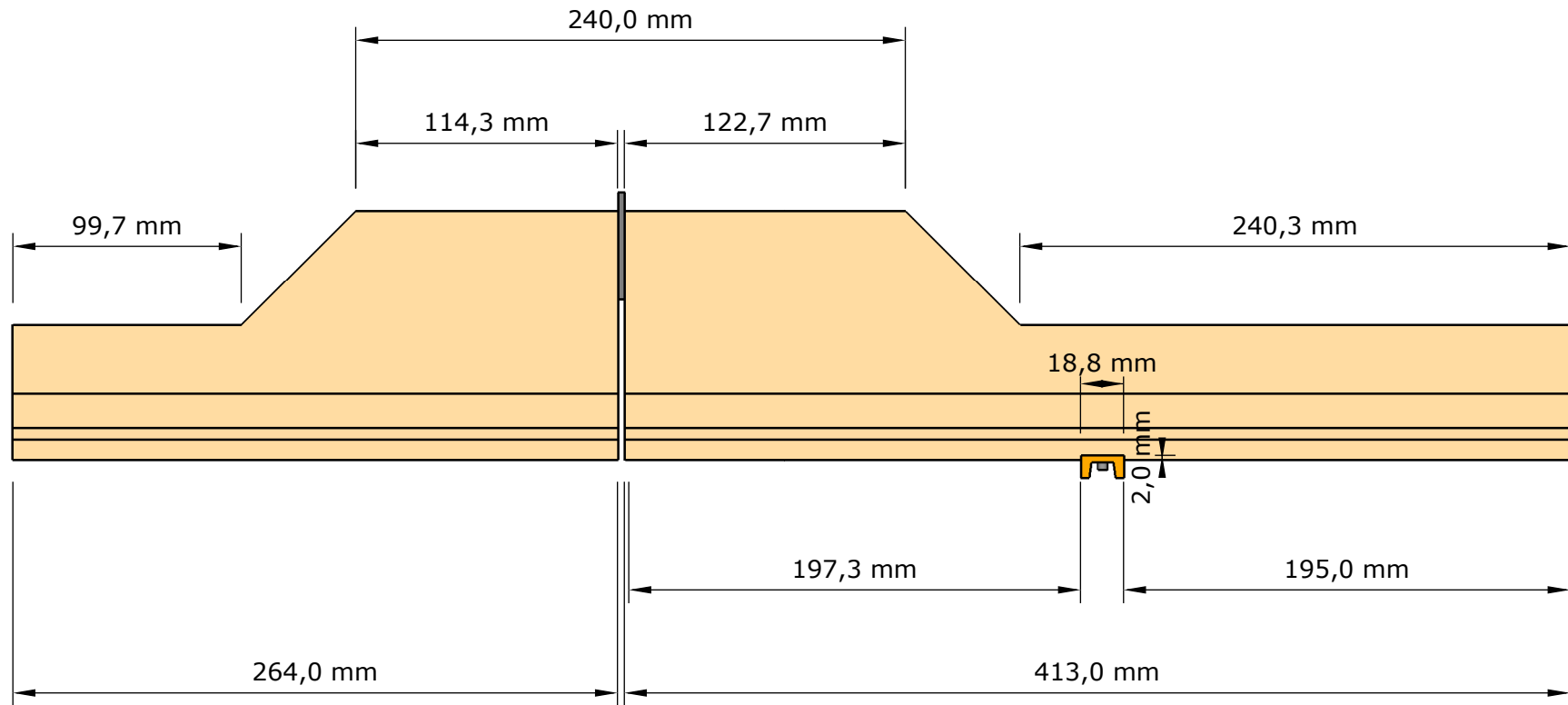

Table Saw Sled - Left 1/2 Scale

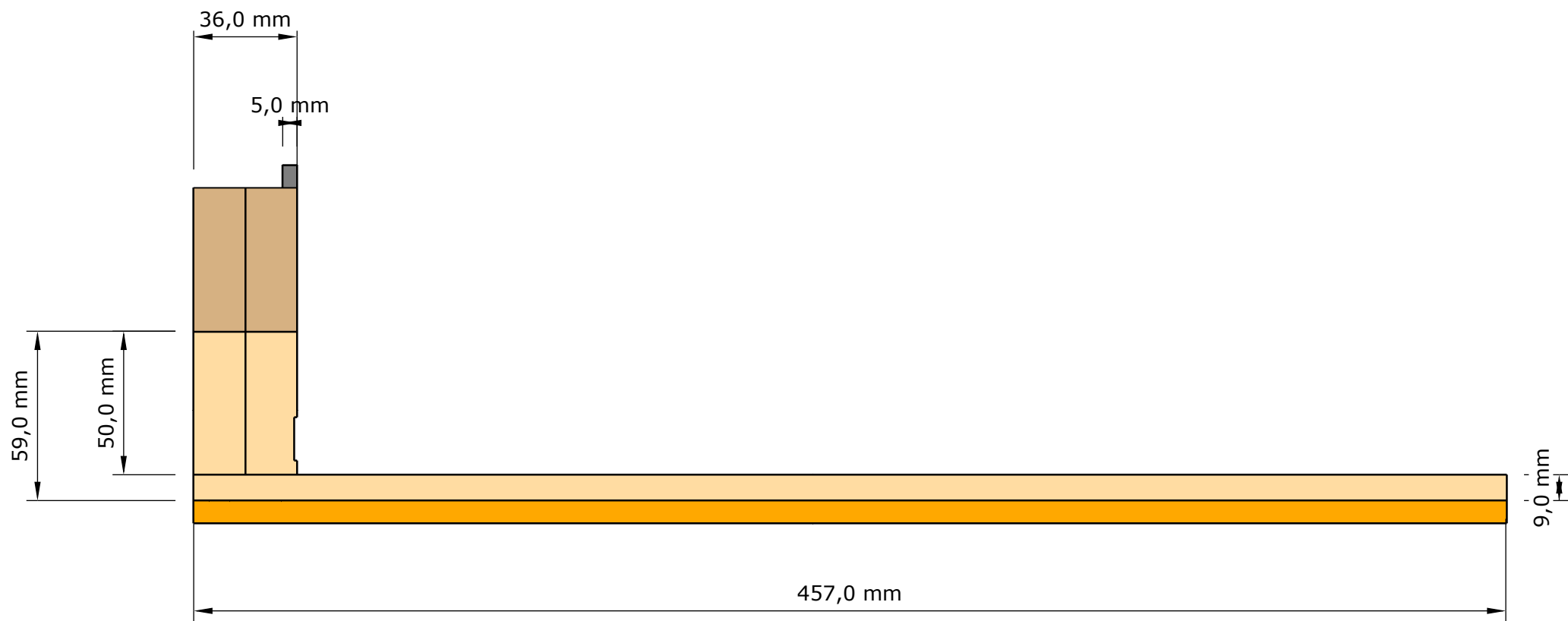

Table Saw Sled - Right 1/2 Scale

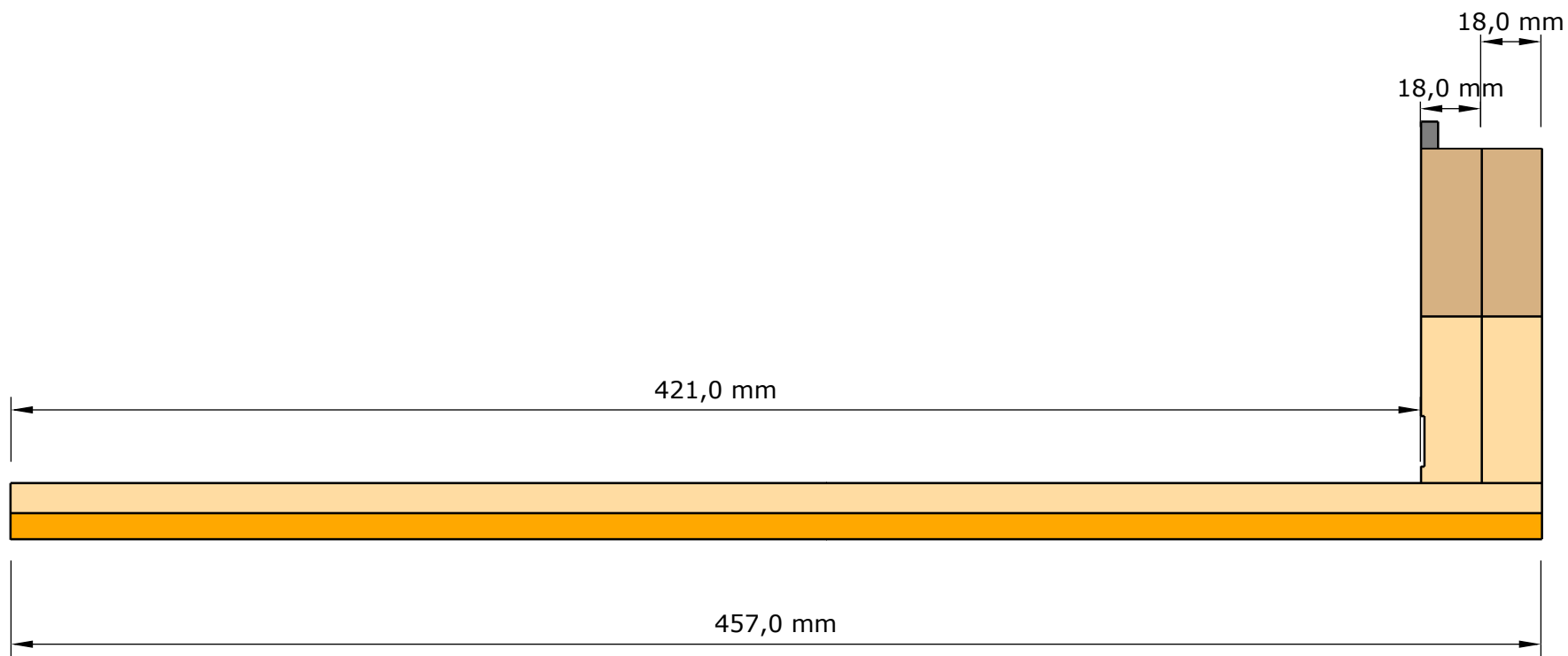

Table Saw Sled - Back 1/3 Scale

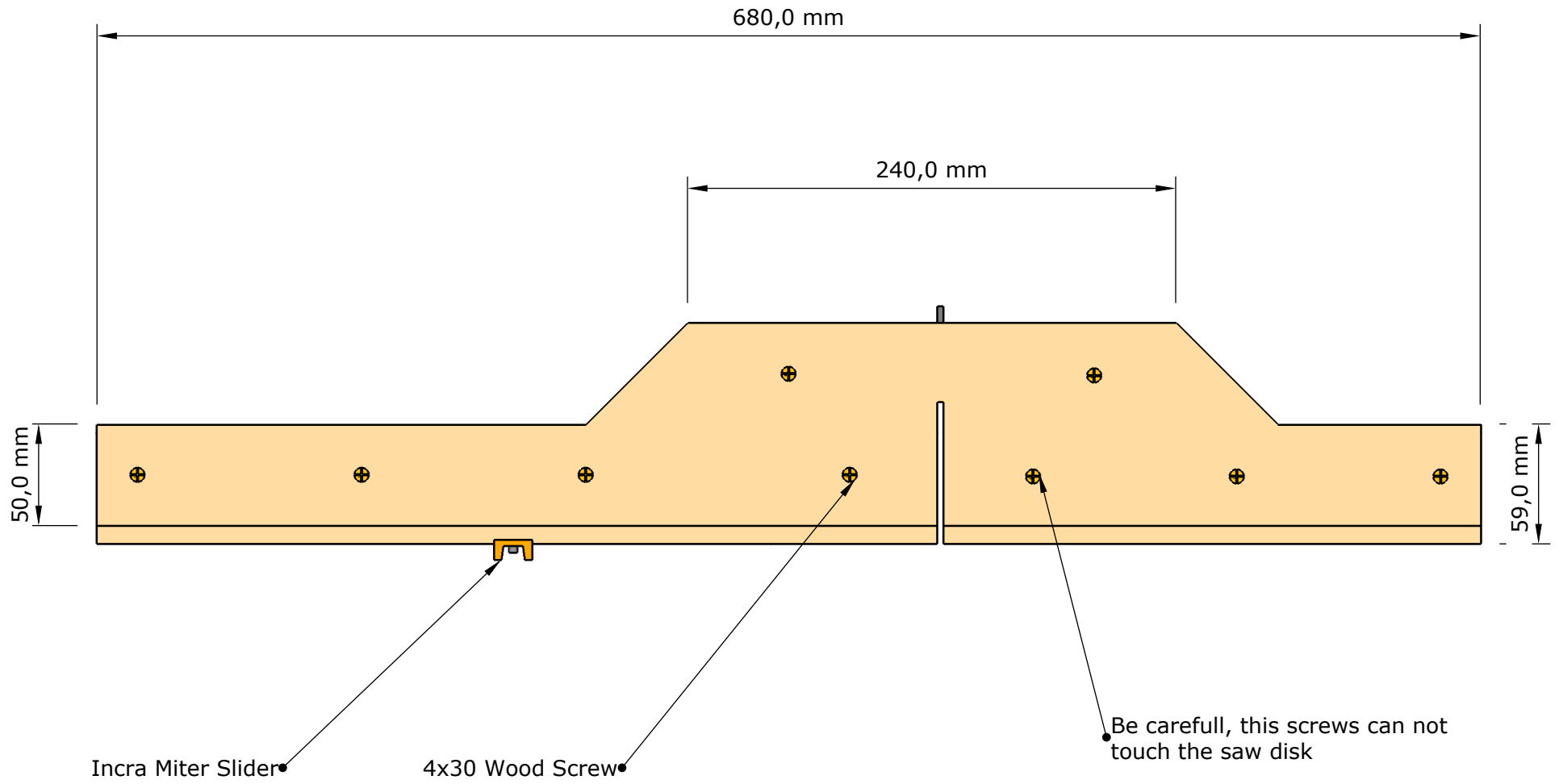

Table Saw Sled X Ray - Left 1/2 Scale

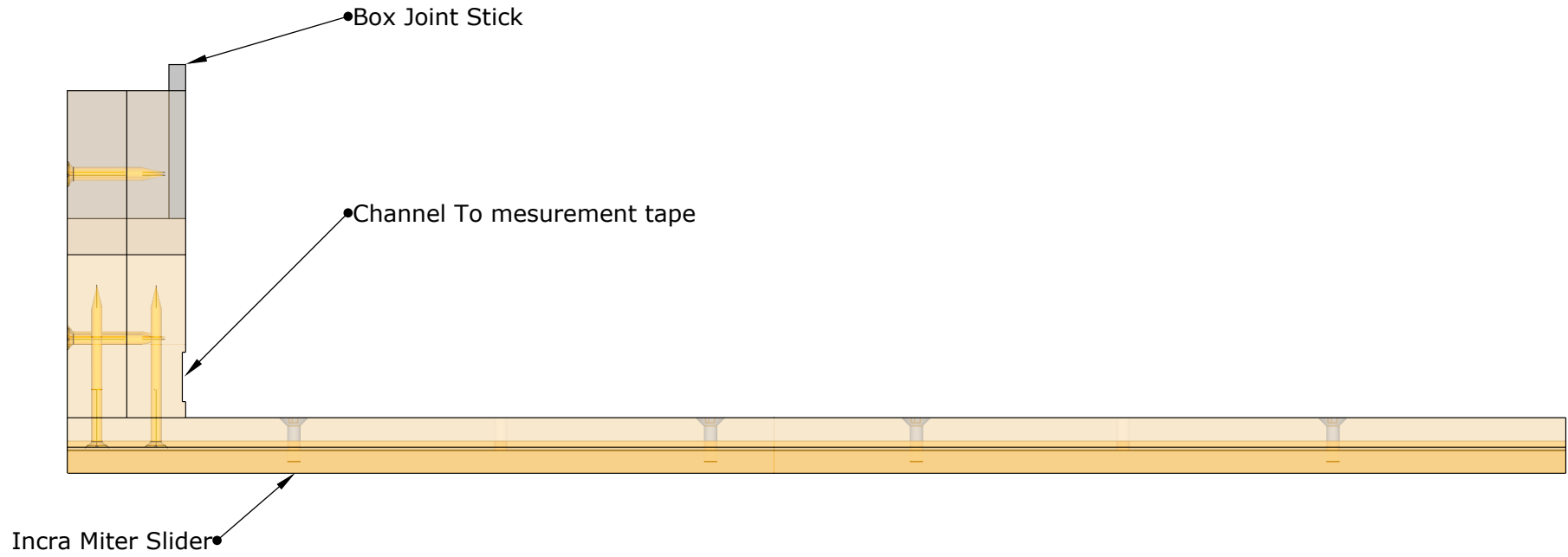

Table Saw Sled

Name	Length	Width	Quantity	Material
50	680 mm	100 mm	2	18mm Plywood
51	680 mm	457 mm	1	9mm Plywood

